

2 PORT MOTORISED VALVE

PMV21 (1") PMV22 (22 mm) PMV 24 (3/4") PMV28 (28 mm)

PRODUCT COMPLIANCE

This product complies with the essential requirements of the following EC Directives:

- Electro-Magnetic Compatibility Directive 2014/30/EU
- Low Voltage Directive 2014/35/EU
- RoHS 2011/65/EU

SAFETY INFORMATION

These instructions are applicable to the SALUS Controls model stated on the front cover of this manual only, and must not be used with any other make or model.

This accessory must be fitted by a Competent person, and installation must comply with the guidance provided in the current editions of BS7671 (IEE Wiring Regulations) and Part 'P' of the Building Regulations. Failure to comply with the requirements of these publications could lead to prosecution.

Always isolate the AC Mains supply before removing or refitting the actuator assembly.

Please leave these instructions with the end user where they should be kept in a safe place for future reference.

INTRODUCTION

A motorised valve is used to control the flow of water in a central heating system. The motorised valve can be used for control of both heating and hot water, and it works by controlling the flow of water from the heating boiler to other parts of the system.

There are two types of motorised valve used in domestic heating systems: two port (also called zone valves), and three port (also called mid position valves). SALUS Controls offers both types of valve in a range of standard port sizes.

FEATURES

- Two port option in 1", 22mm, 3/4" and 28mm sizes
- Removable actuator assembly
- Manual lever and position indicator
- Spring return
- Industry standard wiring



INSTALLATION

Please read the important safety information at the start of this manual before you begin to install the device.

Before Installation

This valve must only be installed in compatible systems. Before installing, please check that:

- The system pipework has been flushed out to remove any residue.
- There is enough clearance around the valve to allow removal and refitting of the actuator.
- The valve is not installed with the actuator facing down.
- The supply voltage is the same as the voltage indicated on the actuator cover.
- The mains water pressure and the pressure differentials between valve ports are suitable for this valve (see Product Specification).

Do not restore the mains supply to the system until all associated items are fully installed.

NOTE: All electrical installation work should be carried out by a suitably qualified Electrician or other competent person. If you are not sure how to install this motorised valve consult either with a qualified electrician, heating engineer or your boiler / heating system supplier for advice on how to continue.

Electrical Connection

The electrical connections to the motorised valve are made using the pre-wired cable. This simplifies installation, as no connections need to be made to the actuator itself. The connecting cable uses industry standard colours, and the connection details are shown below:

Control wire (Power Supply AC 230V) Brown - Live. Blue - Neutral.

Close valve (no water flow): Brown 0V, Blue is N

Open valve (water flow): Brown 230Vac, Blue is N

Auxiliary switch output (COM, NO) Orange = COM. Grey = NO

When valve is open, orange and grey, AUX switch is closed. When valve is closed, orange and grey, AUX switch is open. Yellow/Green wire is for earth.

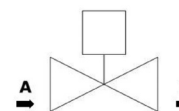
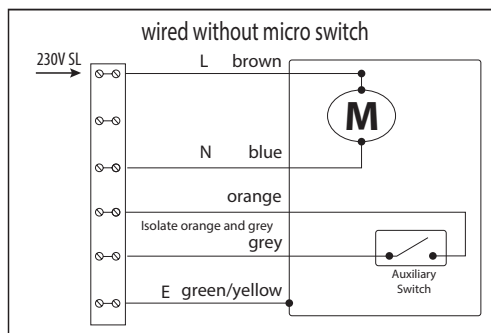
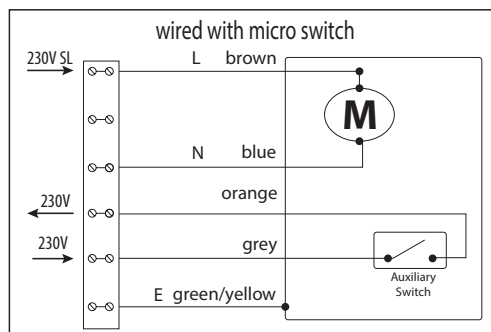

Note: For basic diverter valve applications please isolate/Disregard the orange and Gray wires.

MANUAL LEVER

There is a lever on the side of the actuator cover: this lever allows manual operation of the valve, e.g. for refilling and draining of the system or if the actuator fails. For two way valves, the lever allows the valve to be kept open; with three way valves the lever allows both ports A and B to be open at the same time.

To manually operate the valve, gently push the lever forward and latch it in the MAN position. The valve will automatically return to AUTO when the actuator is powered up again.

NOTE: Push the manual lever slowly to prevent damage to the actuator motor and gear system. The valve should be in manual position to be fitted.



ACTUATOR REMOVAL AND REFITTING

The valve actuator can be removed or refitted without having to disturb the valve installation.

Removal:

1. Remove actuator cover
2. Lock lever in 'MAN' position
3. Loosen 2 securing screws
4. Lift actuator from valve body.

Re-fitting:

1. Remove actuator cover
2. Lock lever in 'MAN' position
3. Turn valve stem to parallel position as indicated
4. Push actuator onto valve
5. Tighten 2 securing screws
6. Release lever and allow to travel back to 'AUTO'

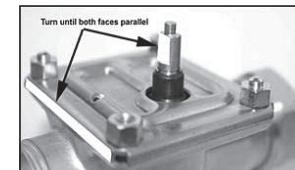
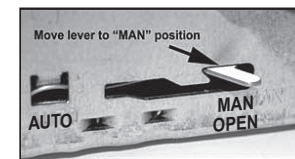

Note: Do not attempt to dismantle the actuator assembly as it contains no user serviceable parts – dismantling or tampering with the actuator assembly will invalidate the product warranty.

MAINTENANCE

The Motorised Valve requires no special maintenance. Periodically, the outer casing can be wiped clean using a dry cloth (please DO NOT use solvents, polishes, detergents or abrasive cleaners, as these can damage the Motorised Valve).

There are no user serviceable parts within the unit; any servicing or repairs should only be carried out by SALUS Controls or their appointed agents.

Should the Motorised Valve fail to function correctly, check:

- The heating system is switched on.
- The lever is not latched in the MANUAL position.

PRODUCT SPECIFICATION

Model: 2 port motorized valve PMV21/22/24/28
Type: Motorised valve designed for domestic heating applications.

Electrical

Switching Voltage: 230V AC / 50Hz
Power Consumption: 6W

Response

Opening: 14 seconds
Closing: 3 seconds

Differential Pressure

Pipe size	2 Way		
22mm	0.8 bar	3/4"	0.8 bar
28mm	0.6 bar	1"	0.6 bar
Max Static Pressure:	8.6 bar		

Operating Temperatures

Min Fluid Temperature: 5 °C
Max Fluid Temperature: 88 °C

Environment

Operating Temperature: -10 °C to +60 °C
Storage Temperature: -20 °C to +65 °C
Protection class: IP20

SALUS CONTROLS PLC, SALUS HOUSE, DODWORTH BUSINESS PARK SOUTH,
WHINBY ROAD, DODWORTH, BARNESLEY S75 3SP.
SALES: T: +44 (0) 1226 323961 • E: sales@salus-tech.com
TECHNICAL: T: +44 (0) 1226 323961 • E: tech@salus-tech.com
www.salus-controls.com

3 PORT MOTORISED VALVE

PMV31 (1") PMV32 (22 mm) PMV34 (3/4") PMV38 (28 mm)

PRODUCT COMPLIANCE

This product complies with the essential requirements of the following EC Directives:

- Electro-Magnetic Compatibility Directive 2014/30/EU
- Low Voltage Directive 2014/35/EU
- RoHS 2011/65/EU

SAFETY INFORMATION

These instructions are applicable to the SALUS Controls model stated on the front cover of this manual only, and must not be used with any other make or model.

This accessory must be fitted by a Competent person, and installation must comply with the guidance provided in the current editions of BS7671 (IEE Wiring Regulations) and Part 'P' of the Building Regulations. Failure to comply with the requirements of these publications could lead to prosecution.

Always isolate the AC Mains supply before removing or refitting the actuator assembly.

Please leave these instructions with the end user where they should be kept in a safe place for future reference.

INTRODUCTION

A motorised valve is used to control the flow of water in a central heating system. The motorised valve can be used for control of both heating and hot water, and it works by controlling the flow of water from the heating boiler to other parts of the system.

There are two types of motorised valve used in domestic heating systems: two port (also called zone valves), and three port (also called mid position valves). SALUS Controls offers both types of valve in a range of standard port sizes.

FEATURES

- Three port option in 1", 22mm, 3/4" and 28mm sizes
- Removable actuator assembly
- Manual lever and position indicator
- Spring return
- Industry standard wiring



INSTALLATION

Please read the important safety information at the start of this manual before you begin to install the device.

Before Installation

This valve must only be installed in compatible systems. Before installing, please check that:

- The system pipework has been flushed out to remove any residue.
- There is enough clearance around the valve to allow removal and refitting of the actuator.
- The valve is not installed with the actuator facing down.
- The supply voltage is the same as the voltage indicated on the actuator cover.
- The mains water pressure and the pressure differentials between valve ports are suitable for this valve (see Product Specification).

Do not restore the mains supply to the system until all associated items are fully installed.

NOTE: All electrical installation work should be carried out by a suitably qualified Electrician or other competent person. If you are not sure how to install this motorised valve consult either with a qualified electrician, heating engineer or your boiler / heating system supplier for advice on how to continue.

Electrical Connection

The electrical connections to the motorised valve are made using the pre-wired cable. This simplifies installation, as no connections need to be made to the actuator itself. The connecting cable uses industry standard colours, and the connection details are shown below:

When A is open & B is closed; water flows out from A;
 When B is open & A is closed; water flows out from B;
 Control wire (Power Supply AC 230V) White - Live. Blue - Neutral
 When A is open & B is closed; white 0V, Blue is N;
 When B is open & A is closed; white 230V, Blue is N;
 Auxiliary switch output (COM, NO) Orange = COM. Grey = NO
 Yellow/ Green wire = Earth

When valve is open, orange and grey AUX switch is closed. When valve is closed, orange and grey AUX switch is open. Yellow/Green wire is for earth.

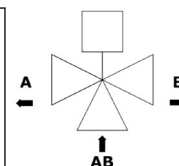
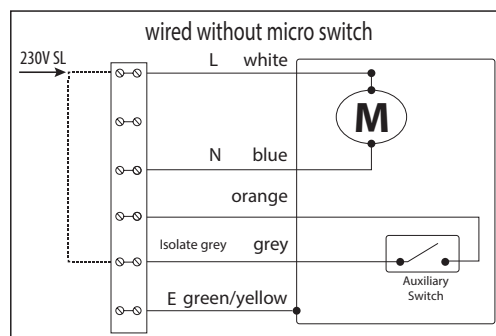
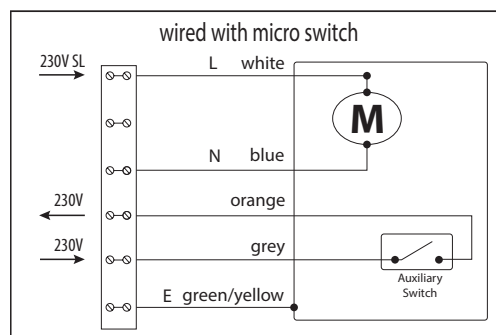

Note: For basic diverter valve applications please isolate / Disregard the orange wire. But connect white and grey together..

MANUAL LEVER

There is a lever on the side of the actuator cover: this lever allows manual operation of the valve, e.g. for refilling and draining of the system or if the actuator fails. For two way valves, the lever allows the valve to be kept open; with three way valves the lever allows both ports A and B to be open at the same time.

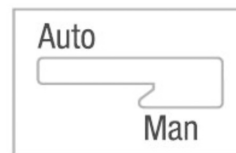

To manually operate the valve, gently push the lever forward and latch it in the MAN position. The valve will automatically return to AUTO when the actuator is powered up again.

NOTE: Push the manual lever slowly to prevent damage to the actuator motor and gear system. The valve should be in manual position to be fitted.

ACTUATOR REMOVAL AND REFITTING

The valve actuator can be removed or refitted without having to disturb the valve installation.

Removal:

1. Remove actuator cover
2. Lock lever in 'MAN' position
3. Loosen 2 securing screws
4. Lift actuator from valve body.

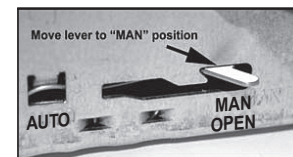

Re-fitting:

1. Remove actuator cover
2. Lock lever in 'MAN' position
3. Turn valve stem to parallel position as indicated
4. Push actuator onto valve
5. Tighten 2 securing screws
6. Release lever and allow to travel back to 'AUTO'

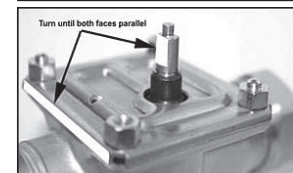

Note: Do not attempt to dismantle the actuator assembly as it contains no user serviceable parts – dismantling or tampering with the actuator assembly will invalidate the product warranty.

MAINTENANCE

The Motorised Valve requires no special maintenance. Periodically, the outer casing can be wiped clean using a dry cloth (please DO NOT use solvents, polishes, detergents or abrasive cleaners, as these can damage the Motorised Valve).

There are no user serviceable parts within the unit; any servicing or repairs should only be carried out by SALUS Controls or their appointed agents.

Should the Motorised Valve fail to function correctly, check:

- The heating system is switched on.
- The lever is not latched in the MANUAL position.

PRODUCT SPECIFICATION

Model: 3 port motorised valve PMV31/32/34/38
 Type: Motorised valve designed for domestic heating applications.

Electrical

Switching Voltage: 230V AC / 50Hz
 Power Consumption: 6W

Response

Opening: 14 seconds
 Closing: 3 seconds

Differential Pressure

Pipe size	3 Way		
22mm	0.8 bar	3/4"	0.8 bar
28mm	0.6 bar	1"	0.6 bar
Max Static Pressure:	8.6 bar		

Operating Temperatures

Min Fluid Temperature: 5 °C
 Max Fluid Temperature: 88 °C

Environment

Operating Temperature: -10 °C to +60 °C
 Storage Temperature: -20 °C to +65 °C
 Protection class: IP20

SALUS CONTROLS PLC, SALUS HOUSE, DODWORTH BUSINESS PARK SOUTH, WHINBY ROAD, DODWORTH, BARNESLEY S75 3SP.

SALES: T: +44 (0) 1226 323961 • E: sales@salus-tech.com
 TECHNICAL: T: +44 (0) 1226 323961 • E: tech@salus-tech.com
 www.salus-controls.com