

Installation & Maintenance Manual

GB 535 / GB 540
GB 3160 / GB 3500

Gas Booster

Contents

Contents

GENERAL.....	3
OPERATION.....	3
ELECTRICAL.....	3
SPARES & COMPONENTS.....	3
OPTIONAL EXTRAS.....	3
BOOSTER / BURNER OPERATING MODES.....	4
Single Booster / Burner Operation.....	4
Single Booster/Multi Burner Operation.....	4
Automatic Twin Duty Standby Operation.....	4
GAS BOOSTER DIMENSIONS.....	5
INSTALLATION INSTRUCTIONS.....	7
Safety.....	7
Delivery.....	7
Installation.....	7
Gas Booster Anti-Vibration Kit.....	8
Electrical Installation.....	8
GAS PRESSURE SWITCHES.....	9
Inlet Gas Pressure Switch.....	9
Outlet Gas Pressure Switch.....	9
MAINTENANCE.....	10
Replacement of the Fan Bearing Assembly.....	10
Drive Motor.....	10
Drive Belt.....	10
Belt and Pulley Replacements.....	11
OPTIONAL EXTRAS.....	12
Acoustic Cover.....	12
Gas Booster Reservoir.....	13
SLOW PRESSURE RAMP UP AND SPEED CONTROL OPTIONS.....	14
INTRODUCTION.....	14
GAS BOOSTER INVERTER DRIVE SYSTEM INSTALLATION GUIDELINES.....	14
PRESSURE TRANSDUCER INSTALLATION SCHEMATIC.....	14
GB3160 / GB3500 VSD GENERAL ARRANGEMENT.....	15
SLOW PRESSURE RAMP UP INVERTER CONTROL AND OPERATION.....	15
SPEED CONTROL INVERTER CONTROL AND OPERATION.....	15
SET UP PROCEDURE FOR DANFOSS VLT MICRO DRIVE.....	16
VSD Booster FC51 VLT Microdrive Parameters.....	17
ELECTRICAL DATA.....	17
PERFORMANCE GRAPH.....	18

GENERAL

A gas booster is required on installations where the required gas burner supply pressure falls below the minimum required for the appliance to achieve full output.

Only qualified gas operatives holding ACS CBHP1 can carry out work on gas boosters, this includes changing gas booster belts. Anyone not holding ACS CBHP1 MUST NOT work on a gas booster as this is classed as interfering with a gas supply, in accordance with The Gas Safety (Installations & Use) Regulations 1988.

Nu-way gas boosters are suitable for use with both natural and clean, dry manufactured gases, giving the performance shown on page 10. The maximum ambient temperature should not exceed 40°C.

Boosters are supplied with an Anti-Vibration Kit as standard.

OPERATION

The booster control enables the booster to work automatically. Gas flow through the booster is required to stop any excessive increase in operating temperature and we recommend that the booster should only operate in conjunction with the burner. Prolonged periods of operation without any gas flow will cause an increase in temperature, shortening the life of the booster and increasing service frequency. If however the plant is required to work under such conditions, consideration should be given to the use of a purpose-designed bypass to dissipate the excess heat and the installation of a twin duty standby system to allow for regular inspection. Where a standby booster is fitted, it should be operated regularly or in rotation. If the booster is operating in rotation auto cycling may have been installed as an option.

Model GB 540 may show some degree of instability of gas flow at very low rates of throughput, or, when this booster serves a long and involved system of pipework. If this situation is anticipated a controlled bypass will overcome the problem.

ELECTRICAL

All models are designed to operate with a 3-phase 400 Volt 50Hz electrical supply, the GB 3160 is also available to suit a single-phase 230Volt 50Hz supply.

Earthing

The anti-vibration mountings effectively insulate the booster unit from the floor and a proper earth connection should be made.

SPARES & COMPONENTS

A full range of spare parts is readily available, should they be needed.

To assist with identification, the full data plate details should be supplied when ordering any spares, including if the unit is three or single phase (GB 3160 only).

OPTIONAL EXTRAS

- **Acoustic Covers**
These are available for all boosters should they be required. For dimensional detail see the Optional Extras section.
- **Gas Booster Pressure Reservoir**
- **Non-Return Valves**

BOOSTER / BURNER OPERATING MODES

Single Booster / Burner Operation

The unit is supplied with all controls fitted and pre-wired, they include a motor starter, inlet gas pressure switch, outlet gas pressure switch, and all necessary burner interlocks needed for a single booster/burner operation.

However, a manual isolating valve (not supplied by Nu-way) must be fitted immediately before the flexible inlet coupling.

Single Booster/Multi Burner Operation

The unit is supplied with all the controls pre-wired and fitted, they include a motor starter, inlet gas pressure switch, outlet gas pressure switch, and all necessary burner interlocks needed for a single booster with up to four burners in operation.

However, a manual isolating valve, not supplied by Nu-way, must be fitted immediately before the flexible inlet coupling.

Automatic Twin Duty Standby Operation

This system comprises of two gas boosters and a separate control panel.

One hand reset inlet gas pressure switch and one gas pressure switch are fitted to each booster.

The pressure switches are to be wired to the control panel in accordance with the wiring diagram supplied with the booster.

All necessary electrical equipment needed for the operation of two boosters with up to four burners in operation is contained within the control panel. Changeover to the standby booster in the event of a failure of the booster is automatic.

Manual isolating valves and non-return valves (not supplied by Nu-way) must be fitted to comply with IGE/UP/2.

Note: Non-return valves are available from Nu-way.

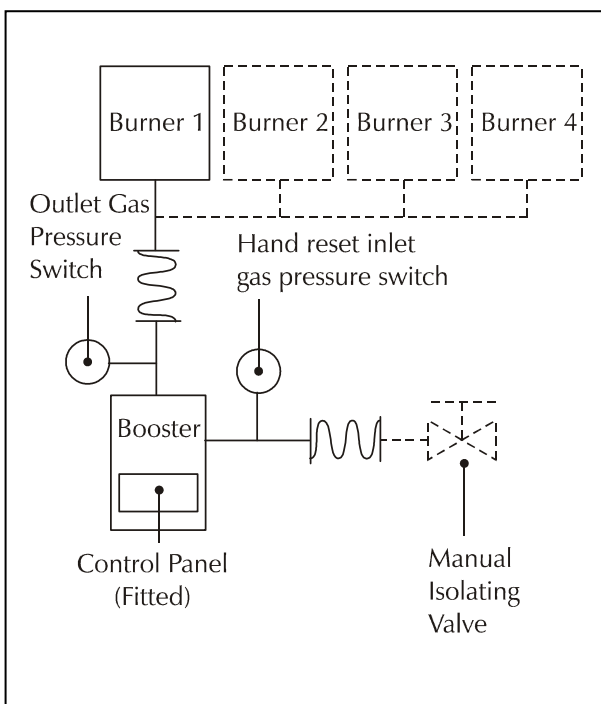

Single Booster / Multi Burner

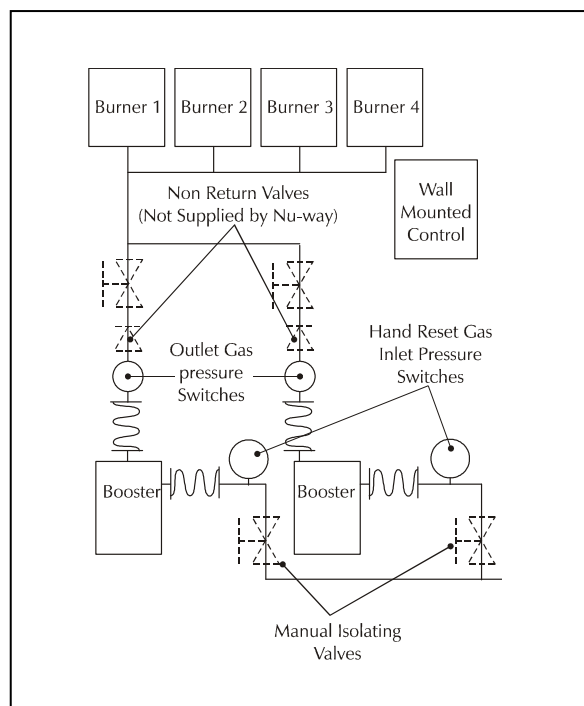

Automatic Twin Booster Duty & Standby

GAS BOOSTER DIMENSIONS

GB 3160 & GB 3500 (Single Booster with Panel)

Dimensions (mm)

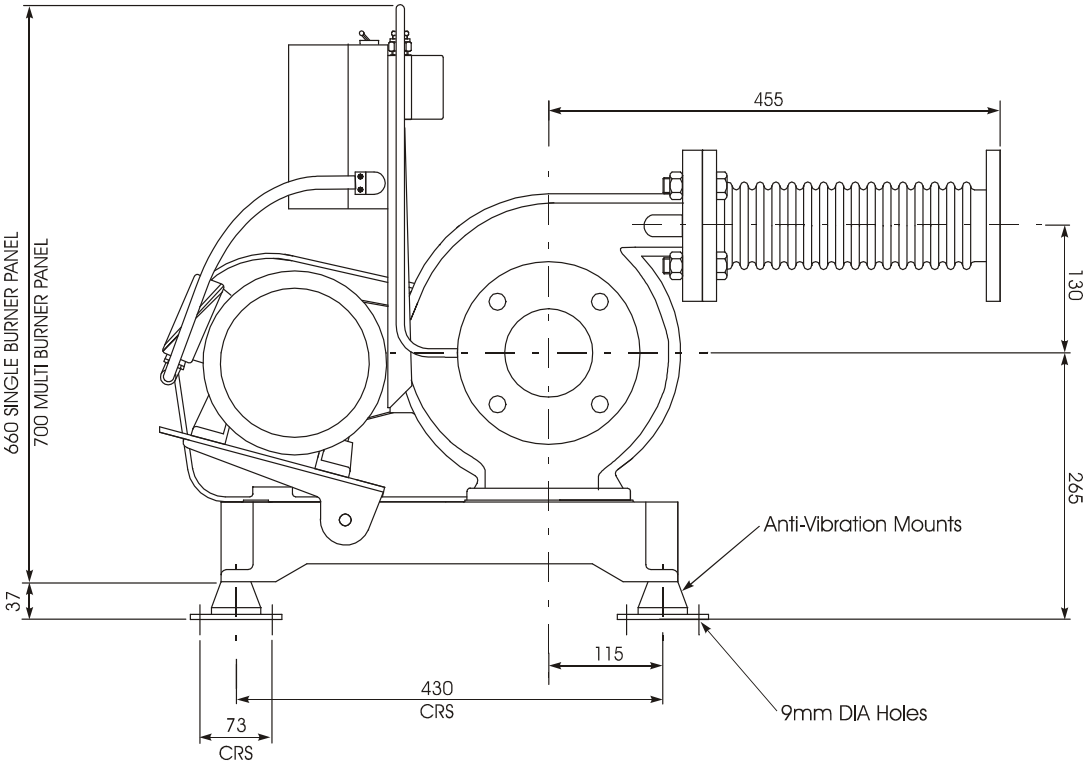
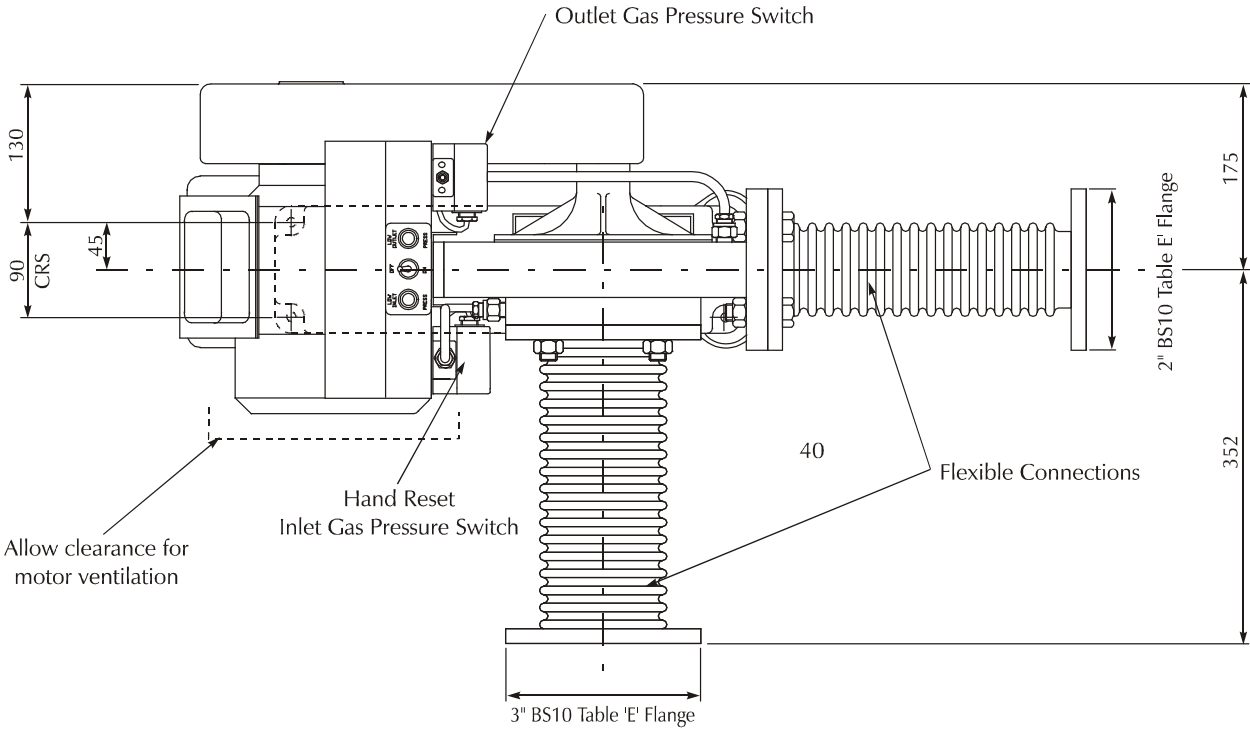

Approximate Dimensions (mm) for separate panels

Operation	Height	Width	Depth
Automatic twin duty standby	500	500	500

GB 540/1-3 (Single Booster with Panel)

Dimensions (mm)

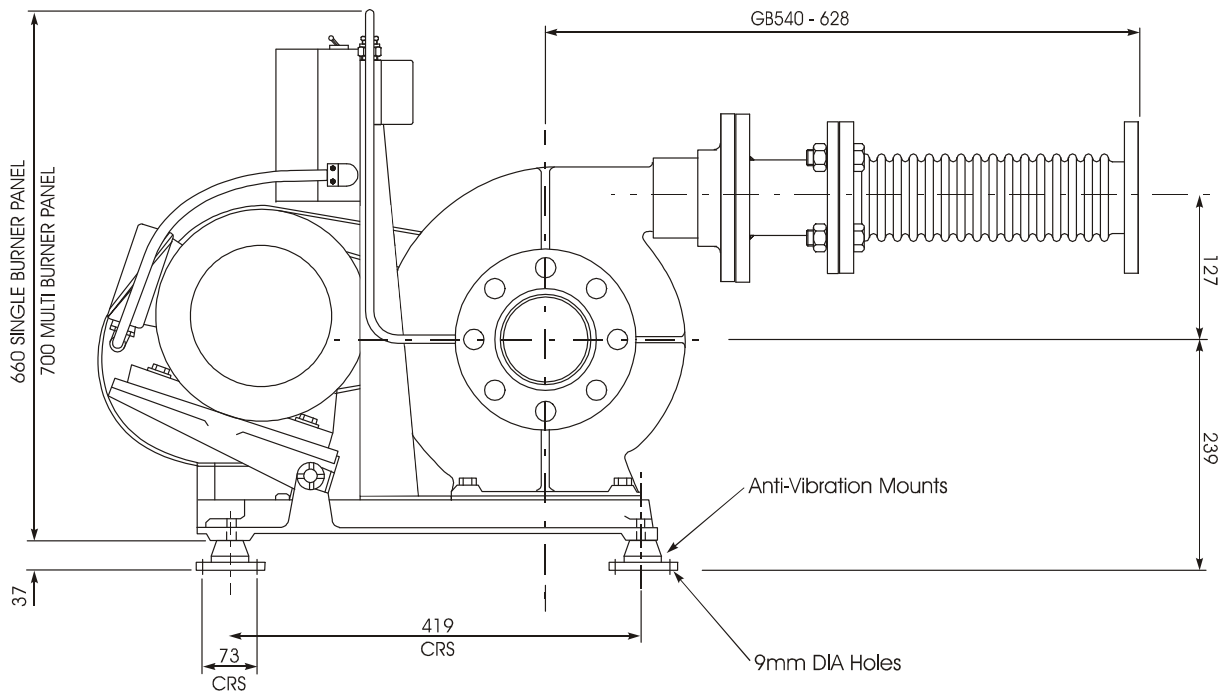
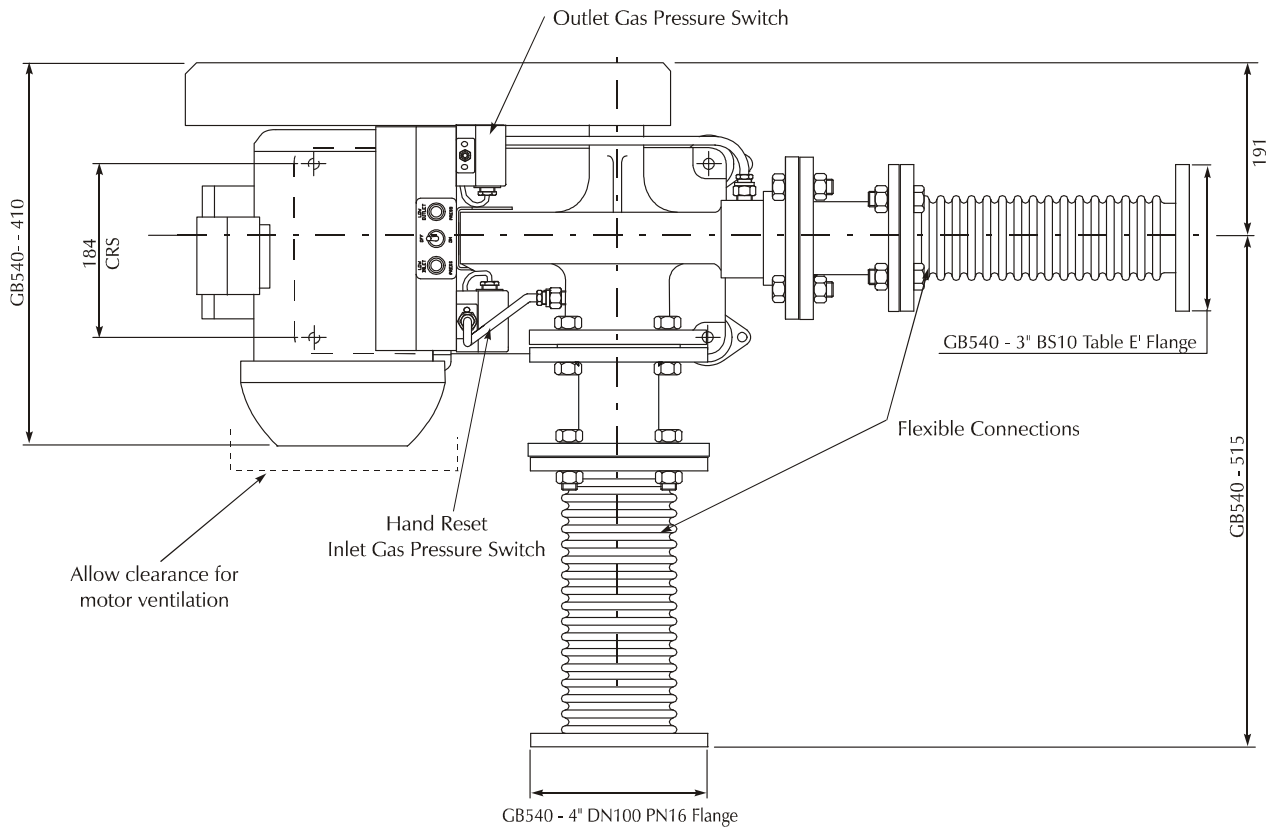

INSTALLATION INSTRUCTIONS

Safety

Boosters are tested for gas tightness during manufacture using air pressure and should be protected from any hydraulic pressure when testing on site. Hydraulic pressure applied to the fan chamber will result in damage to the bearing assembly.

This unit is specially designed for ease and speed of on-site installation. It has been run and is pressure tested ready to fit. Note that all usual safety precautions must be taken when fitting this appliance. In the UK it must be installed and maintained by a Gas Safe registered engineer. In export markets it must be installed by qualified personnel according to local legal requirements and regulations.

The fact that gas boosters have been installed and operated for many years does not guarantee a safe and adequate installation. As with all engineering units, regular maintenance and checks are essential.

Delivery

Check the booster and ancillary equipment to ensure that damage has not occurred during transit.

Installation

Boosters and all ancillary equipment should be installed to meet the requirements of all relevant standards and practices, including the Institute of Gas Engineers Publication IGE/UP/2.

It is recommended that Nu-way gas boosters are positioned as close to the combustion equipment as is reasonably possible, in non-hazardous atmospheres where the ambient temperature will not exceed 40°C, but must not be installed in governor or meter rooms.

The installation site must be well ventilated but free of excessive dust and have sufficient free area around the booster for servicing. The booster should be placed on a firm, flat and horizontal surface using anti-vibration mountings, and all connecting pipework should be well supported and accurately positioned to prevent strain on the casing.

Flexible inlet and outlet connectors must be fitted between the booster ports and the pipework, these will serve to eliminate strain on the case and reduce noise during operation. Stress should not be put onto the gas booster casing by using fixed pipework to the inlet and outlet connections.

Anti-vibration mountings must be used.

Abrasive particles and dust from building operations are particularly harmful to this equipment and under such conditions the unit should be regularly cleaned, particularly the belt and pulleys.

The pipework and fittings adjacent to the booster should be sized to give minimum pressure loss. (Details of pressure loss through flexible connectors can be found on page 10).

Pressure switches and test points should not be sited in areas of excessive turbulence.

Electrical connections to the motor terminal box should terminate in a short length of flexible conduit to ensure free movement of the motor platform.

Gas Booster Anti-Vibration Kit

General

The Nu-way gas booster anti-vibration kit is standard supply. For a twin duty standby unit, two kits will be required.

Installation

Flexible connections and anti-vibration mountings should be installed in accordance with Codes of Practice.

Note: Flexible connections are NOT designed to take up large amounts of misalignment; they are being supplied in this instance as anti-vibration devices only.

Kit Contents

- 1 off Inlet Flexible Connector
- 1 off Outlet Flexible Connector
- 2 off Inlet Gasket
- 2 off Outlet Gasket
- 4 off Anti-Vibration Mountings
- 4 off M8 Set Pin and Washer
- 4 off M12 Set Pin and Nut
- 8 off M8 x 30 Rawl Plug Thru-bolt

Electrical Installation

Always ensure that the motor data plate details coincide with the electricity supply.

Electric cables should terminate in short lengths of flexible conduit before entering the booster terminal box.

A correctly sized fuse must be fitted.

Check the rotation of the motor. This should be clockwise when viewed from the rear of the motor, do not however run the booster with inlet and outlet in free air as this may overload the motor. Check that the movement of the motor platform is not restricted.

Check the wiring scheme allows the booster to operate as recommended in the Operation section of this manual on page 1.

GAS PRESSURE SWITCHES

The booster is supplied with gas pressure switches (as required), they are either fitted to the rear of the control panel, or in the case of duty standby systems mounted on a bracket above the booster.

The purpose of the switches is to monitor the inlet and outlet pressures. Adjustment of the switches is achieved by removal of the clear plastic cover and turning the dial to the required setting. They should be adjusted as follows:-

Inlet Gas Pressure Switch

This hand reset type switch is a mandatory requirement and MUST NOT be set below the statutory (UK) minimum of 10 mbar.

In use, this switch will stop the booster should the inlet gas supply pressure fall below 10 mbar. An indication of failure is given both within the switch and on top of the electrical panel, also a facility for remote indication is provided.

Manual resetting of this switch is required when the gas pressure is restored; this is achieved by pressing the red button via the small soft plastic panel in the lid.

If problems are experienced due to a momentary low pressure when the plant starts up, a booster inlet reservoir may be required, see detail on page 8.

Outlet Gas Pressure Switch

This switch is not a mandatory requirement but it is provided on duty & standby units to initiate the changeover if the lead booster fails.

On stand-alone boosters the outlet pressure switch can be added as an extra should indication of low outlet pressure be required.

To adjust this switch fit a manometer to register the outlet pressure being boosted when the burners are all at high fire, the switch should then be adjusted to between 80% and 90% of this pressure.

An indication of a failure is given at the top of the electrical panel, also a facility for remote indication is provided. Reset is automatic when the outlet pressure is restored.

Note: **When used within twin booster standby systems the switches must be fitted between the booster outlet and the non-return valve.**

MAINTENANCE

Experience has shown that maintenance of booster units can be overlooked or undertaken in an inadequate manner. Such practice can lead to the failure of the bearing and fan units.

It is essential that a regular inspection is completed, that the booster is kept in a safe working order and maintained in accordance with good engineering practice.

Particular attention should be paid to the bearings, fan seals, and drive elements.

Replacement of the Fan Bearing Assembly

It is not possible to extract the fan, bearings or other parts of the fan assembly without causing damage and seriously impairing the safety of this high speed unit. The fan bearings and gas seals are of particular importance and have an estimated life of three to five years. The bearings are lubricated for this life expectancy and must not have further lubrication applied.

Normally, the first sign of bearing failure is an increase of operational noise or vibration. Further examination can be made of the radial and axial movement of the impeller shaft, however this requires the removal of the guard and belt. The relevant instructions given on page 7 should be consulted.

When the fan assembly requires replacement the complete Nu-way unit must be substituted and fitted in accordance with the instructions supplied with the kit. Care must be taken not to over-tighten the bearing securing nuts as this can damage the fan chamber.

For replacement, we recommend the use of the Nu-way kits:-

<u>Model</u>	<u>Part Number</u>
GB 3160 / GB 3500	U90993N
GB 540	G10016Y

The kits comprise of a sealed and pre-tested fan unit with drive pulley, inlet and outlet gaskets, together with pressure switch pipework to convert older models of booster.

Drive Motor

Life sealed bearings are fitted and no maintenance is required until they need replacing.

Drive Belt

The drive belt and pulleys should be kept clean, free from grease or dirt, and replaced on an annual basis or immediately if wear or damage is found.

Do not apply a belt dressing under any circumstances.

The motor mounting assembly ensures correct belt tension, the spring supporting the motor platform is factory set and must not be tampered with.

If the drive belt is thrown from its pulley this could indicate possible bearing wear or other malfunction in the booster drive system which must be investigated and corrected. The flat belt drive is a safety feature and therefore alternative types or sizes of pulley must not be fitted under any circumstances. To obtain replacement belts quote the booster model number.

Belt and Pulley Replacements

When ordering spares the full data plate details should be supplied.

To replace these items the following procedure should be adopted:-

- Switch off and isolate the booster power supply, remove the belt guard.
- Support the weight of the motor platform and remove the existing belt.
- Clean or replace the pulleys (see note below).
- Still supporting the weight of the motor platform, position the new belt with the smooth face on the pulleys, ensuring that the belt is flat and not twisted.
- Manually spin the pulleys two or three times and check that the belt runs centrally on the pulley face.
- Replace the belt guard and reinstate the electrical supply and switch on booster.

Note: **If the pulleys are damaged or worn they should be replaced immediately to avoid undue wear of the belt.**

If the pulley is to be changed:-

- Remove the retaining screw, one per pulley, and draw off with an extractor taking care to avoid any undue strain to the bearing assembly.
- Fit replacement pulleys, ensuring that the alignment is correct and firmly tighten the securing screws on the shaft.
- Replace the belt as detailed above.

Always carry out a recognised gas leak test on completion of any operation that has disrupted gas pipework or seals.

OPTIONAL EXTRAS

Acoustic Cover

Dimensions (mm)

NOTE:
Do not obstruct any of the apertures in this cover.
Dimensions are to assist with installation only.
Do not attempt to reproduce

	GB 3160 & GB 3500	GB 540
A	510	610
B	650	700
C	720	900
D	474	585
E	255	260
F	270	270
G	400	425

Gas Booster Reservoir

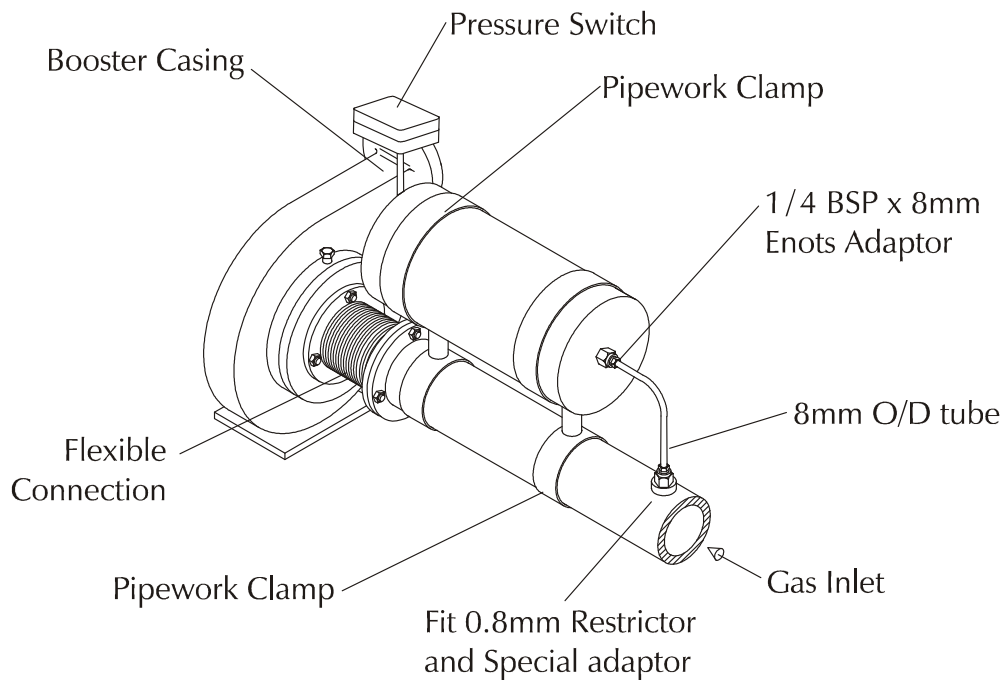

The gas pressure to the booster must not fall below 10 mbar. Some sites may suffer from transient drops in pressure possibly caused by a slow reaction time of the gas meter. In such instances a reservoir may be installed in the sensing line to the inlet gas pressure switch. This will prevent nuisance tripping of the pressure switch due to transient pressure changes, but will ensure safe shutdown in the event of a drop in inlet pressure. A reservoir is available from Nu-way (Part No. T99-057E), contact Nu-way Sales Dept.

The Gas Booster Reservoir Kit comprises of;

- 1 x reservoir
- 2 x pipe brackets
- 1 x pressure switch
- 2 x 8mm OD 'bundi' tube
- 3 x 1/4" BSP 'enots' brass fittings
- 1 x 1/4" BSP special adaptor with 0.8mm restrictor hole
- 1 x 1/4" BSP plug

Installation

1. Isolate the gas and electrical supplies to the gas booster.
2. Fit the gas reservoir in a suitable position on the upstream gas supply pipework using the pipework brackets provided.
3. Fit the 8mm OD 'bundi' tube to the upstream end of the reservoir and mark the fixing position of the special adaptor and restrictor.
4. Make a 1/4" BSP hole in the upstream gas pipework and install the Special adaptor and 0.8mm restrictor and fit the bundi tube.
5. Fit the pressure switch to the downstream end of the reservoir using the enots fittings and bundi tube.
6. Remove the electrical cable from the original inlet pressure and reconnect to the new pressure switch on the reservoir.
7. Remove the original inlet pressure switch and blank hole with 1/4" BSP plug provided.
8. Reconnect the gas and electrical supplies and purge the gas installation before use.

SLOW PRESSURE RAMP UP AND SPEED CONTROL OPTIONS

INTRODUCTION

The gas booster can be fitted with an inverter controller to provide Slow Pressure Ramp Up to reduce the pressure reduction on the upstream gas pipework and equipment. This device can be programmed to control the gas booster to ramp up to full speed from x seconds to y seconds.

An optional Speed Controller (Inverter Drive System) is recommended for installations where the gas pressure at the booster outlet is required to be maintained at a constant level or where the gas booster is supplying multiple small gas burning equipment and the gas volume demand can vary significantly.

GAS BOOSTER INVERTER DRIVE SYSTEM INSTALLATION GUIDELINES

The Inverter Drive units are an integral part of the control panel and it is recommended that these are installed as part of a new gas booster installation or a new control panel installation.

The installation of the pressure transducer should be as shown in the following schematic for the Speed Control option.

PRESSURE TRANSDUCER INSTALLATION SCHEMATIC

The pressure sensor / transducer must be installed at least 5 x Pipe Diameters distance downstream of the outlet flexible connection to ensure stable flow and pressure at the point of sensing.

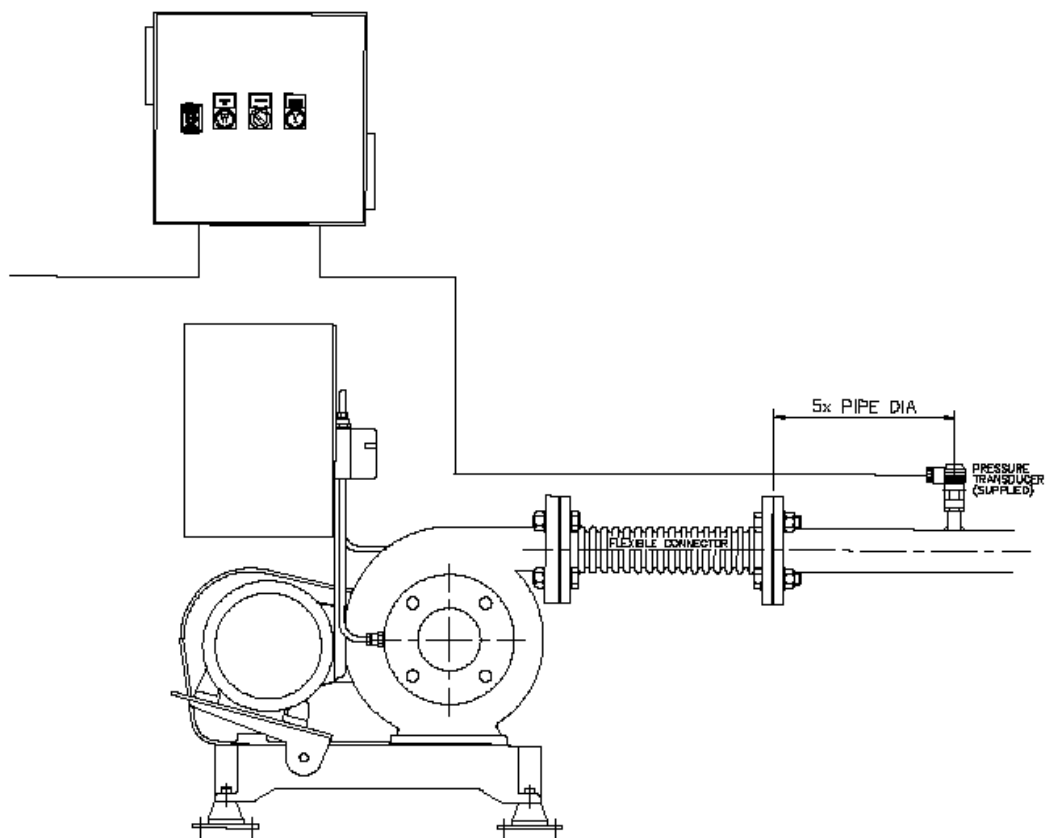

GB3160 / GB3500 VSD GENERAL ARRANGEMENT

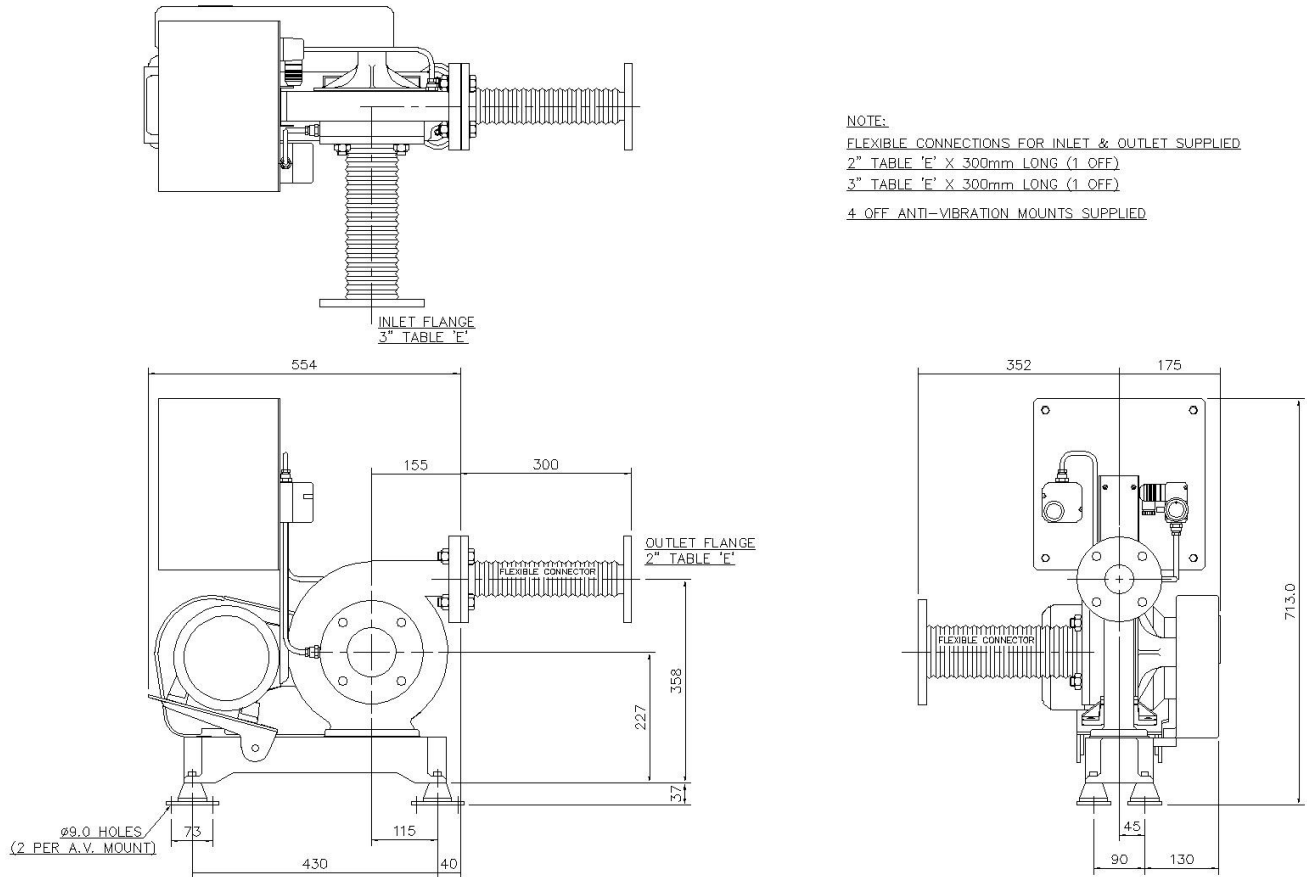

SLOW PRESSURE RAMP UP INVERTER CONTROL AND OPERATION

The function of the Slow Pressure Ramp Up inverter control system is to control the time taken for the gas booster to reach full speed. This is controlled by entering the required ramp up time in the controller (see SET UP PROCEDURE FOR DANFOSS VLT MICRO DRIVE- default set to 10 seconds).

SPEED CONTROL INVERTER CONTROL AND OPERATION

The functioning of the speed control inverter control system is to control the speed of rotation of the gas booster impellor to maintain a controlled downstream pressure as the gas flow rate varies, dependant on the load requirements of the appliances supplied by the booster.

The inverter is able to modulate the booster motor speed by varying the supply frequency between 20Hz and 50Hz

At the control limits of 20Hz and 50Hz the booster outlet pressure may vary slightly to that required, dependant on gas flow.

SET UP PROCEDURE FOR DANFOSS VLT MICRO DRIVE

(Refer to Danfoss Operating Instructions and Programming Guide)

Set switch 4 on s200 to voltage (U) for thermistor. The switches are accessible when the terminal cover is removed (see page 14-15 in the operating instructions, note ON=I, OFF=U)

Power up the VSD and press “Menu” PB on keypad until “Quick Menu” is highlighted to enter the “Quick Set-up” menu below (see page 10 in the Programming Guide);

- 1-20 Motor Power (kW)/(HP)
- 1-22 Motor Voltage (V)
- 1-23 Motor Frequency (Hz)
- 1-24 Motor Current (A)
- 1-25 Motor Nominal Speed (RPM)
- 1-29 Skip this parameter
- 3-02 Minimum Reference – set to 20 Hz
- 3-03 Maximum Reference – set to 50 Hz
- 3-41 Ramp up time – typically 10 sec for testing
- 3-42 Ramp down time – typically 10 sec for testing

Carry out “Local control test” by pressing “Hand On” PB on keypad to start motor and control speed with up/down arrows. Press “Off” PB to stop motor (see page 19 in the operating instructions).

The reference scaling value, PI control and thermistor set-up parameters now need to be entered. These can only be entered from the main menu (see page 10 in the programming guide).

To enter the main menu press “Menu” PB on keypad until “Main Menu” is highlighted and use the up/down arrows and “OK” PB to access the menu group required. Press the up/down arrow to adjust to the required value and press “OK” to enter. Either press up/down arrow to reach another parameter in the same group or back to return to parameter groups and back again to return to the status screen.

VSD Booster FC51 VLT Microdrive Parameters

Parameter Number	Setting	Description
1-00	3	Process Mode
1-62	0 %	Slip Compensation
1-90	2	Thermistor Trip
1-93	1	Thermistor on input 53
3-10	xx %	Setpoint (% of 0-50Hz)
3-15	0	Reference Resource 1 no function
3-16	0	Reference Resource 2 no function
4-10	0	Motor clockwise only
4-14	50	Motor speed top limit
5-11	2	Input 19 coast inverse
5-40	6	Relay active dive running no warning
6-22	4 mA	Terminal 60 Low current
6-23	20 mA	Terminal 60 High current
6-24	0	Terminal 60 Low feedback
6-25	50	Terminal 60 High feedback
7-20	2	Process feedback resource terminal 60
7-32	xx Hz	Process start speed
7-33	2	PI proportional gain
7-34	4	PI integral time

ELECTRICAL DATA

Burner Model	Motor		3 Phase Supply		HRC Fuse (A)	1 Phase Supply		Weight (kg)
	kW	hp	Start Current A Phase	Run Current A Phase		Start Current	Run Current	
GB 3160	0.75	1	11.0	2.0	10	40.0	5.0	34
GB 3500	1.5	2	18.0	3.2	16	Not offered		37
GB 540/1-3	4	5.5	45.0	8.5	25	Not offered		71

PERFORMANCE GRAPH

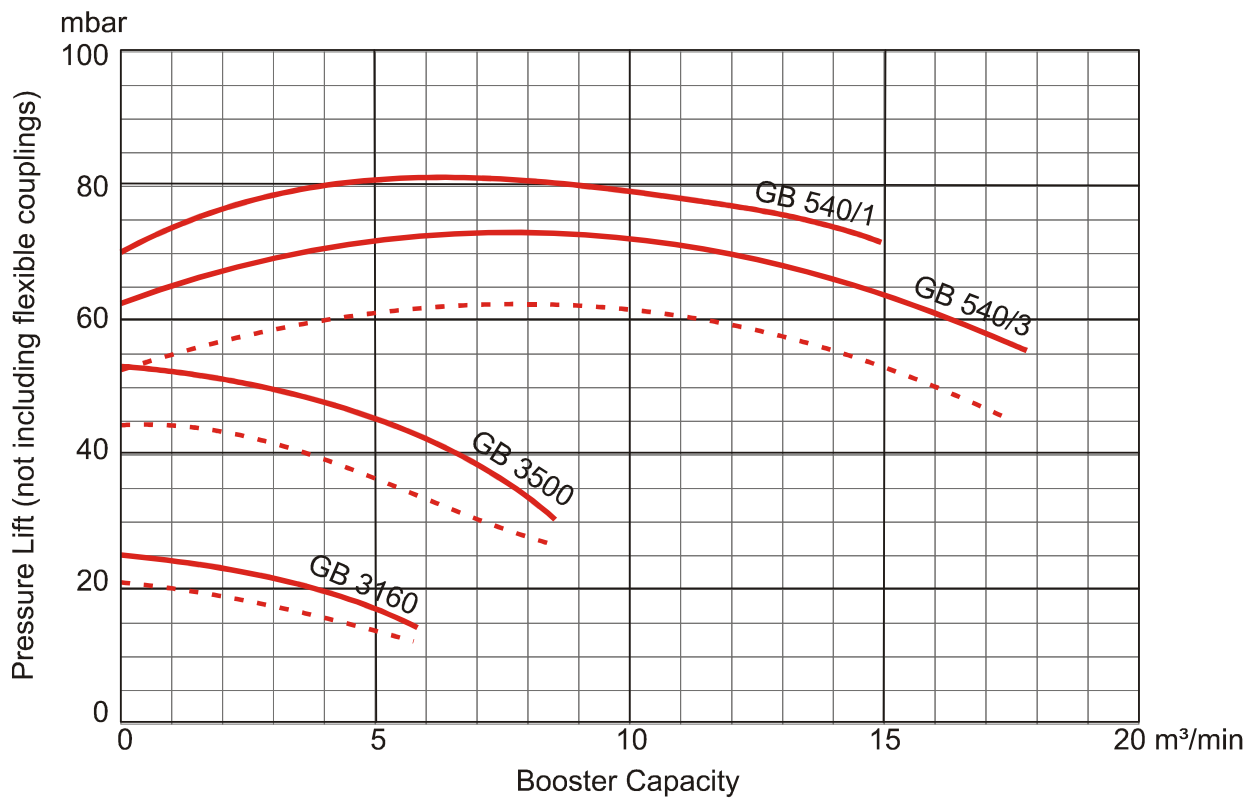

Pressure Drop for Nu-way Supplied Flexible Couplings

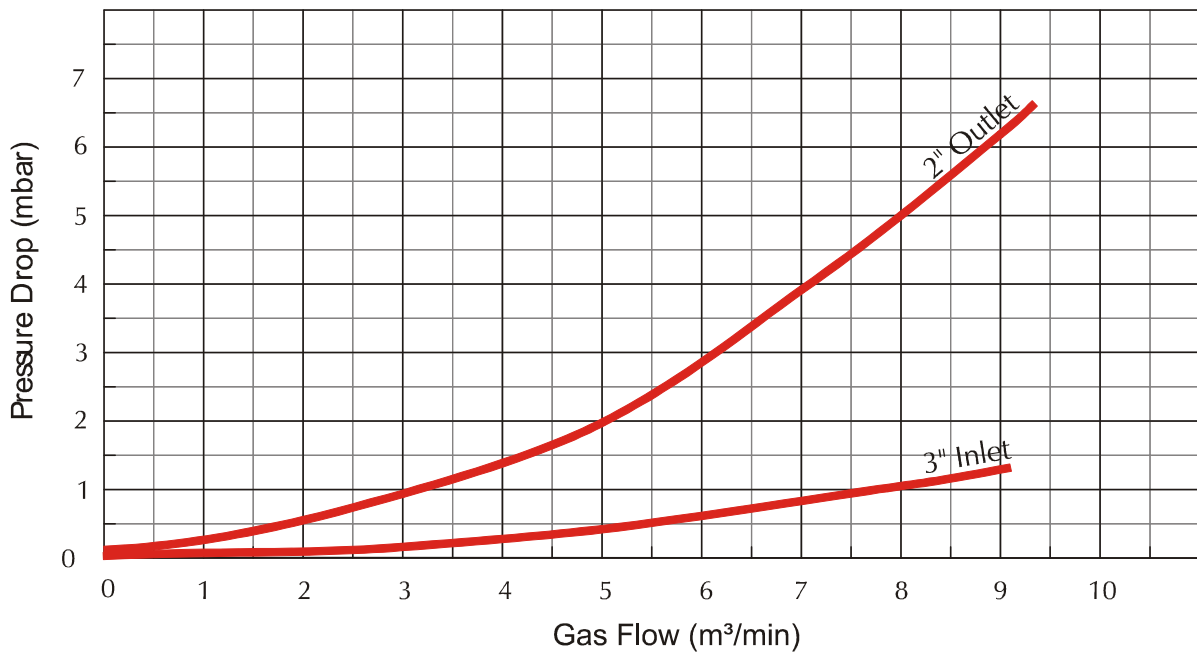

——— Natural Gas - - - - - Towns Gas (SG-0.5)

NOTES

Enertech Limited,
P O Box 1,
Vines Lane
Droitwich,
Worcestershire,
WR9 8NA

Tel: +44 (0) 1905 794331 **Fax:** +44 (0) 1905 794017
Email: info@nu-way.co.uk **Web:** www.nu-way.co.uk

